



January 20, 2025

Version 1.1

Unigen's Cupcake Edge AI Server delivers a fully integrated platform for Machine Learning and Inference AI in a compact and rugged enclosure. Cupcake has the right combination of I/O Interfaces and Expansion Capabilities to capture and process video and multiple types of signals through its POE ports and then to deliver the processed data to the client either over a wired or wireless network. Supporting Neural Networks from the leading ISV providers, Cupcake delivers the flexibility to allow custom solutions.

Selector Guide

Processor	<input type="checkbox"/> Intel Elkhart Lake (Atom X6414RE)	
Memory DDR4 SO-DIMM Base is 2400 Speed 3200 Speed is available	<input type="checkbox"/> 4GB <input type="checkbox"/> 8GB	<input type="checkbox"/> 16GB <input type="checkbox"/> 32GB <input type="checkbox"/> 2400 Speed <input type="checkbox"/> 3200 Speed
Storage Type	<input type="checkbox"/> High Endurance SATA <input type="checkbox"/> High Capacity NVMe	
Storage Capacity	<input type="checkbox"/> 32GB <input type="checkbox"/> 64GB <input type="checkbox"/> 128GB <input type="checkbox"/> 256GB <input type="checkbox"/> 512GB	<input type="checkbox"/> 960GB <input type="checkbox"/> 1.92TB <input type="checkbox"/> 3.84TB <input type="checkbox"/> 7.68TB
WiFi – M.2 2230	<input type="checkbox"/> Yes	<input type="checkbox"/> No
4G – M.2 3042	<input type="checkbox"/> Yes	<input type="checkbox"/> No
5G – M.2 3042	<input type="checkbox"/> Yes	<input type="checkbox"/> No
AI Module	<input type="checkbox"/> Blaize P1600 <input type="checkbox"/> Degirum	<input type="checkbox"/> Hailo-8 <input type="checkbox"/> Hailo-8 x 2 <input type="checkbox"/> MemryX
Rugged Enclosure	<input type="checkbox"/> Yes	<input type="checkbox"/> No
Branding	<input type="checkbox"/> Unigen	<input type="checkbox"/> Custom (Please specify)

Included Features/Interfaces

System	
CPU	Intel® Atom® x6414RE Processor SoC
Memory	16GB DDR4 2400 SO-DIMM
Graphics	Intel® UHD Graphics
Storage	64GB SSD
Ethernet	GbE x 1, GbE x4 with POE+ (Max 30W total power)
Audio	Mic in x 1, Line out x 1
Display	HDMI 2.0b x 1
USB	USB 3.1 Type A x 2 USB Type C for CPU console
Expansion Slot	Micro SD card slot x 1 M.2 2230 E-key x 1 (AI or WiFi) M.2 2242/2280 M-key x 1 (SATA III/PCIe Gen 3.0) M.2 3042/3052 B-key x 1 (4G/LTE or 5G Modem) E1.S 4-lane PCIe 3.0 x 1 (EDSFF) for AI or Storage Micro SIM slot x 1
I/O Placements	
Power	12V DC-IN connector and power button
Reset	Reset button
Debug port	USB-C to UART
COM	D-Sub 9-pin connector x 1 selectable RS232/RS485
CAN	3-Pin terminal block header
Power	12V DC 10A
Security	TPM 2.0
OS Support	Linux, Microsoft
Dimension	170mm x 158mm x 49.5mm
Operating Temperature	0°C ~ 50°C

Non-AI Performance

Passmark Tests (Non-AI Performance)	Score (Composite: 1227.8 Marks)
Storage Performance	1692 Marks
Memory Performance	1036 Marks
CPU Performance	2181 Marks
Low End Graphics	59.3 Marks
Cinebench	739.3
WinRAR I/O	1714 KB/s

FCC, CE, VCCI, KC definitions

FCC

This equipment has been tested and found to comply with the limits for a Class A digital device, pursuant to part 15 of the FCC Rules. These limits are designed to provide reasonable protection against harmful interference when the equipment is operated in a commercial environment. This equipment generates, uses, and can radiate radio frequency energy, and if it is not installed and used in accordance with the instruction manual, it may cause harmful interference to radio communications. Operation of this equipment in a residential area is likely to cause harmful interference in which case the user will be required to correct the interference at his own expense.

CE

The products described in this manual comply with all applicable European Union (CE) directives if it has a CE marking. For computer systems to remain CE compliant, only CE-compliant parts may be used. Maintaining CE compliance also requires proper cable and cabling techniques.

VCCI Class A Statement

この装置は、クラス A 情報技術装置です。この装置を家庭環境で使用すると電波妨害を引き起こすことがあります。この場合には使用者が適切な対策を構ずるよう要求されることがあります。

VCCI-A

VCCI (Class B) Compliance Statement for Users in Japan

この装置は、情報処理装置等電波障害自主規制協議会 (VCCI) の基準に基づくクラス B 情報技術装置です。この装置は、家庭環境で使用することを目的としていますが、この装置がラジオやテレビジョン受信機に近接して使用されると受信障害を引き起こすことがあります。

取り扱い説明書に従って正しい取り扱いをして下さい。

Korea Communications Commission (KCC) Statement

이 기기는 업무용(A급)으로 전자파적합기기로서 판매자 또는 사용자는 이 점을 주의하시기 바라며, 가정외의 지역에서 사용하는 것을 목적으로 합니다.

This is electromagnetic wave compatibility equipment for business (Type A). Sellers and users need to pay attention to it. This is for any area other than home.

Cupcake Certification Labels

Cupcake Features

Front

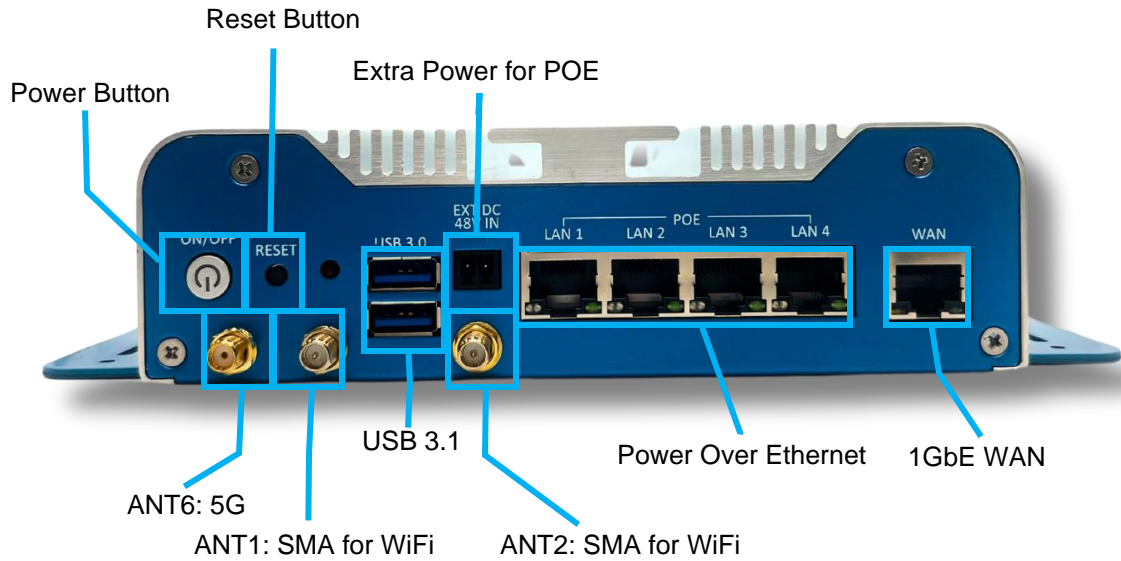

Back

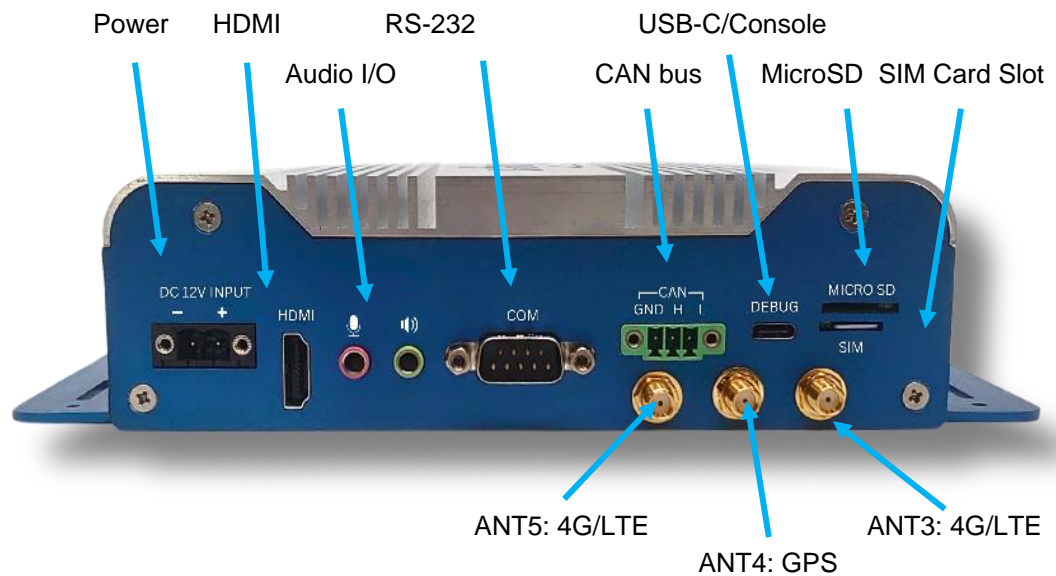

External Connection Interfaces and Definitions

Front:	Power On	Power push button
	Reset Button Switch	Reset push button

	USB 3.0	Dual USB3.0 Gen1 Type-A connector
	60W External PoE Power Input	(Reserved)
	POE	RJ-45 Gigabit Ethernet connector (PoE PD function)
	GbE (WAN)	RJ-45 Gigabit Ethernet connector
	Wi-Fi Antenna Connectors	
Back:	Power Connector	12V/10A 2-Pin (Insert Connector Type)
	HDMI 2.0	
	Audio I/O	
	COM	
	CAN Bus	
	UART Console	USB Type-C connector
	Micro SD Card Interface	
	SIM Card Interface	
	4G/5G/LTE and GPS Connectors	

Front:

Power Button:

**Reset Button/Switch:****USB 3.0:**



Location	Front
Type	Type-A USB connector
Pin	Refer to USB Standard

60W External POE Power Input (reserved)



GbE Ethernet Switch with POE (IEEE 802.3at)

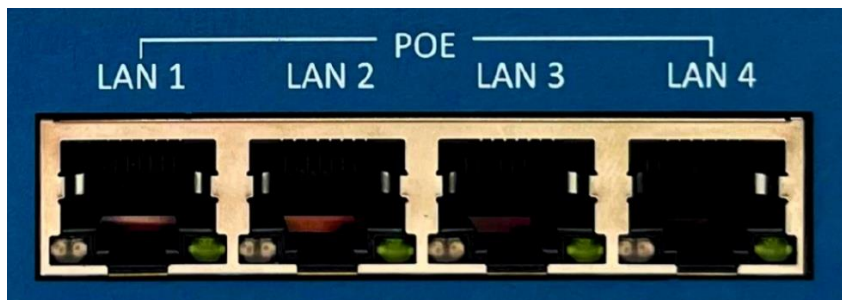

Location	Front
Type	RJ-45 Connector
Pin	Refer to Ethernet Standard
Description	Support for IEEE 802.3

GbE (WAN):



Location	Rear
Type	RJ-45 Connector
Pin	Refer to Ethernet Standard

2x2 Wi-Fi Antennae Connectors:

ANT1 and ANT2 (small antennas) connect to the Wi-Fi

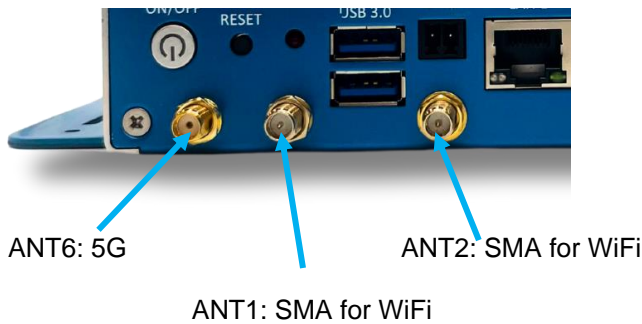

Back:

Power Connector: DC12V/10A Input:



HDMI:

The Digital Display Ports support HDMI V2.0 interface, connection supports up to Up to 3840 x 2160 @60Hz

Audio I/O:

Audio connector: Microphone IN, Speaker OUT

CAN Bus:

CAN Bus connector: GND, CANH, CANL

USB-C:

System debug port

There is a USB-C to UART that connects to the CPU's serial console. Pin out info is shown below.

Pin No.	Function	Pin No.	Function
1	+V5	2	USB_DATA-
3	USB_DATA+	4	NC
5	GND		

RS232 Interface:



There is one RS232 Serial ports (COM1).

The pin assignments are listed in the following table:

COM Port	Pin No.	RS-232
1	1	-----
	2	RXD
	3	TXD
	4	-----
	5	GND
	6	-----
	7	RTS
	8	CTS
	9	-----

Micro SD Card Slot & SIM Card Slot:

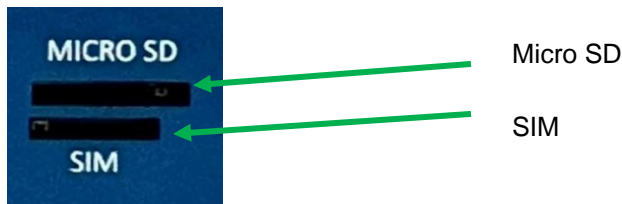

LTE/4G/5G and GPS Antennae Connections:

Connect ANT 3 (MAIN) and ANT 5 (DIV) for 4G/LTE modem; ANT4 is for GPS only.

For 5G modem, install 4 antennas on ANT3, ANT4, ANT5, ANT6

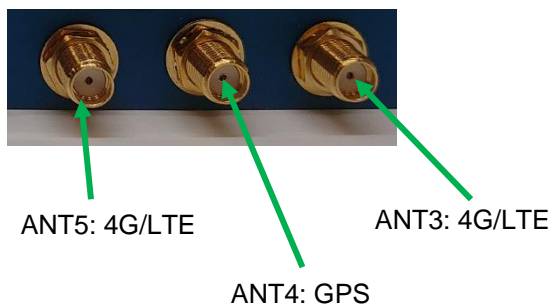

Internal HW Interfaces*

* For reference only, warranty will be void if box is opened.

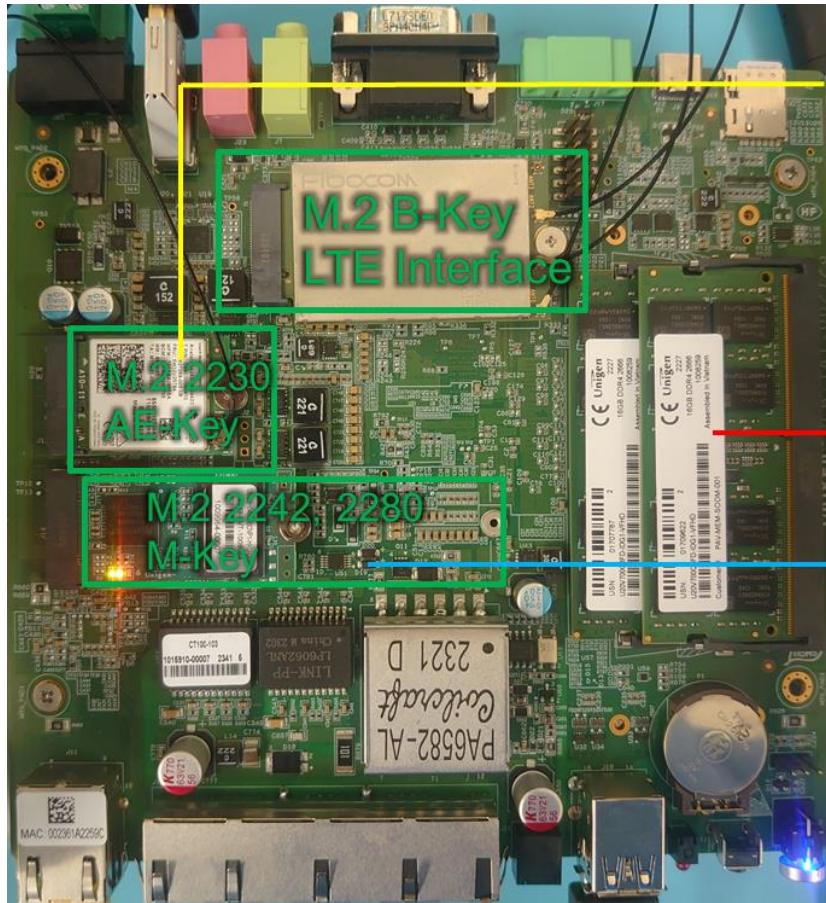

Wi-Fi or AI Interface

Dual DDR4 SO-DIMM

M.2 2242, 2280 M-Key SATA/PCIe SSD Interface Boot or Data SSD's

Spec for M.2 Interfaces: [PCI Express M.2® Specification Revision 5.0, Version 1.0](#)

Module Nomenclature

Type XX XX - XX - X - X

Width (mm)	Length (mm)	Component Max Ht. (mm)		
		Top Max	Bottom Max	
12	16	S1	1.20	0.00
16	26	S2	1.35	0.00
22	30	S3	1.50	0.00
30	42	D1	1.20	1.35
	60	D2	1.35	1.35
	80	D3	1.50	1.35
	110	D4	1.50	0.70
		D5	1.50	1.50

Key ID	Pin	Interface
A	8-15	2x PCIe x1/USB 2.0/12C/DP x4
B	12-19	PCIe x2/SATA/USB 2.0/USB 3.0/HSIC/SSIC/Audio/UIM/12C
C	16-23	Reserved for Future Use
D	20-27	Reserved for Future Use
E	24-31	2x PCIe x1/USB 2.0/IC2/SDIO/UART/PCM
F	28-35	Future Memory Interface (FMI)
G	39-46	Generic (Not used for M.2)
H	43-50	Reserved for Future Use
J	47-54	Reserved for Future Use
K	51-58	Reserved for Future Use
L	55-62	Reserved for Future Use
M	59-66	PCIe x4/SATA



Spec for E1.S Interface:

EDSFF Interface Specification for E1.S	SFF-TA-1009
Enterprise and Datacenter Standard Form Factor Pin and Signal Specification	PUBLISHED SFF-TA-1009 R3.1.pdf

Internal HW Options

WiFi Card and Specifications in Table:

M.2 2230 AE Key

LTE 4G/LTE, 5G Module:

M.2 3042/3052 B Key

Storage SSD:

M.2 2242 to M.2 2280 (SATA and NVMe)

Storage Type	DRAMless	With DRAM Onboard
SATA	M.2 2242 (32GB – 256GB) DRAMless, pSLC High Endurance	
PCIe/NVMe	M.2 2280 (500GB, 1TB) DRAMless (TLC)	M.2 2280 (480GB, 960GB, 1.92TB, 3.84TB) w/DRAM, High Performance (TLC)

AI Options

Brand	Module Type	Specialty
Hailo (Hailo-8)	E1.S (Single Chip and Dual Chip)	Performance (26 and 52 TOPs)
Blaize (P1600)	E1.S	Performance and ML
DeGirum (Orca)	M.2 (on M2 to E1.S Adapter)	Very Low Power
Brainchip (Akida)	M.2 (on M2 to E1.S Adapter)	Machine Learning/Low Power
DeepX	M.2 (on M2 to E1.S Adapter)	High Performance (23 TOPs)

Software Sections: General Software

Ubuntu Setup

Cupcake 2 is shipped pre-installed with Ubuntu 22 as the factory OS. It will be based on Ubuntu 22.04 Desktop version; the Linux Kernel is updated to support peripherals on the motherboard.

Once the power button is pushed, Cupcake 2 will boot into the Ubuntu OS. The default super user password is Unigen123\$.

Network Interfaces

Cupcake 2 comes pre-configured as a gateway which can forward LAN devices network traffic to GE WAN (default). The 4G/LTE, 5G network and WiFi 6E modules shown below are optional.

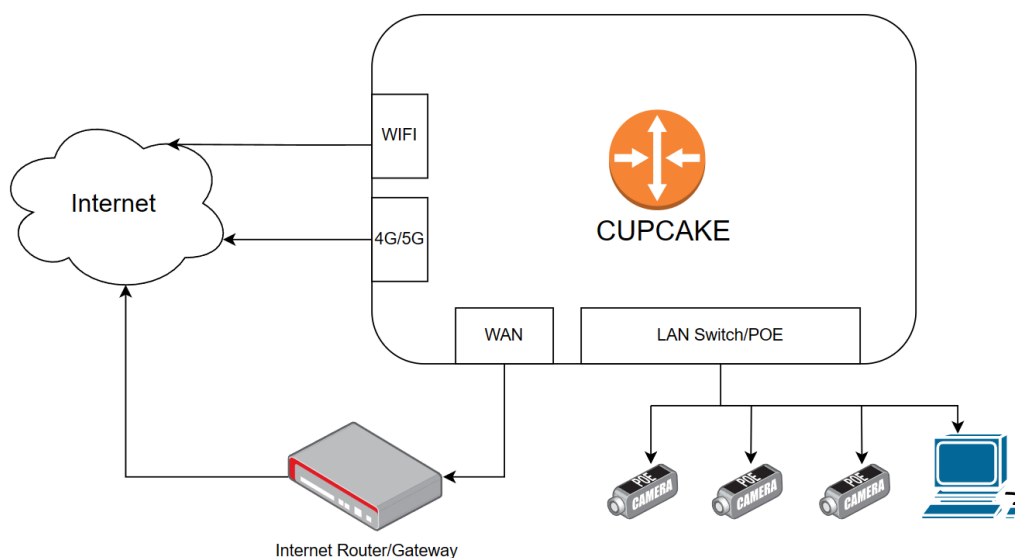

Wired Network

Cupcake 2 uses **netplan** to configure WAN/LAN port IP addresses.

The following is the pre-configured IP address and range for the Ethernet switch port.

WAN port: **enp0s29f1**

WAN IP: DHCP Auto or Manual set via Ubuntu's NetworkManage's GUI.

LAN Switch/POE port: **enp0s29f2**

LAN IP: 192.168.5.1/24

LAN IP subnet: 192.158.5.0/24

LAN DHCP Client IP range: 192.168.5.150 192.168.5.200

If necessary, the **netplan** configuration file can be edited to change the IP address.

```
sudo nano /etc/netplan/00-network-manager-all.yaml
```

1. Then Make **netplan** setting take effect

```
sudo netplan apply
```

2. check the adapter ip address

```
sudo ip addr
```

DHCP Server

DHCP service package is pre-installed for the ethernet switch ports. The IP address range has been set to 192.168.5.150 through 192.168.5.200.

If necessary, the range can be changed by updating the `/etc/dhcp/dhcpd.conf` file.

1. Use below command to modify `/etc/dhcp/dhcpd.conf`

```
sudo nano /etc/dhcp/dhcpd.conf
```

The content will look like this:

```
default-lease-time 600;
max-lease-time 7200;
subnet 192.168.5.0 netmask 255.255.255.0 {
  range 192.168.5.150 192.168.5.200;
  option domain-name-servers 192.168.5.1; 8.8.8.8;
  option routers 192.168.5.1;
}
```

2. Restart DHCP service.

```
sudo systemctl restart isc-dhcp-server
```

3. Show dhcp server running status/log.

```
sudo service isc-dhcp-server status
```

4. View dhcp client list

```
sudo dhcp-lease-list
```

WiFi

WiFi Configuration: please use Ubuntu's Network Manager GUI to set up.

Routing Function

The Ethernet switch PoE ports' network traffic will be routed to GE WAN port by default.

If the network traffic needs to be routed to 4G or 5G cellular interface, please contact Unigen.

4G Fibocom FM101 (optional)

4G network adapter model Number - Fibocom FM101, the device driver is pre-installed if ordered.

1. Insert SIM card when power is OFF.
2. Config Mobile Network in Ubuntu Setting Menu.
3. Use "ip addr" to show network connection status.

5G Fibocom FM160 – Dial-up Networking (optional)

It can support 5G/4G/LTE bands.

1. Please check if module driver loaded correctly.

```
sudo lsmod | grep mhi
```

```
root@cupcake2-System-Product-Name:/home/cupcake2/fibocom# lsmod | grep mhi*
fibo_mhi          196608  0
```

```
sudo ls /dev/mhi*
```

```
root@cupcake2-System-Product-Name:/home/cupcake2/fibocom# ls /dev/mhi*
/dev/mhi_AT /dev/mhi_AUDIO /dev/mhi_BHI /dev/mhi_DIAG /dev/mhi_DUN /dev/mhi_EFS /dev/mhi_GNSS /dev/mhi_LOOPBACK /dev/mhi_QMIO
root@cupcake2-System-Product-Name:/home/cupcake2/fibocom#
```

2. Dial for WAN connection

Open a terminal, use the commands below to make a data connection.

```
cd ~/5GModem/fibo_mhi/src
sudo ./fibocom-dial -s "access_point name" -d /dev/mhi_QMIO
```

Use correct "access_point name" (APN) based on your service provider.

For example, the APN for T-mobile is fast.t-mobile.com, you can use below command –

```
sudo ./fibocom-dial -s "fast.t-mobile.com" -d /dev/mhi_QMIO
```

For At&T, you can use

```
sudo ./fibocom-dial -s Broadband -d /dev/mhi_QMIO
```

For Verizon, you can use

```
sudo ./fibocom-dial -s vzwinternet -d /dev/mhi_QMIO
```

3. Check for WAN connection.

Once the dial successfully gets IP address. You can ping 8.8.8.8 to check the connection.

4. You can use “ctrl+c” to turn off the data connection. Then use the same command to reconnect.

```
sudo ./fibocom-dial -s "access_point name" -d /dev/mhi_QMI0
```

CAN Bus

To use CAN, you will need to install can-utils

```
sudo apt install -y can-utils
```

Check if can device exists:

```
ifconfig can0
```

After you connect to another CAN device, use following command to config CAN bus baudrate: change [CAN_BAUDRATE] to your value. E.g. 1000000 (1M)

```
sudo ifconfig can0 down
sudo ip link set can0 type can bitrate [CAN_BAUDRATE]
sudo ifconfig can0 up
```

Now you can use cansend and candump commands to send and receive CAN Bus messages.

```
cansend can0 123#11.2233.44556677.88
candump can0
```

RS-232

Run following command to get the device for RS-232:

```
ls /sys/bus/pci/devices/*11.0/tty | grep tty
cupcake2@cupcake2-System-Product-Name:~$ ls /sys/bus/pci/devices/*11.0/tty | grep tty
ttyS4
```

Then use your favorite serial tool to communicate through /dev/ttyS4. E.g.

```
sudo picocom -b 115200 /dev/ttyS4
```

Temp-sensor

Temperature sensor is connected to IIC, its address is 0x49.

Run following command to get the IIC bus:

```
ls /sys/bus/pci/devices/*/i2c_designware.6*/ | grep i2c
cupcake2@cupcake2-System-Product-Name:~$ ls /sys/bus/pci/devices/*/i2c_designware.6*/ | grep i2c
i2c-8
```

Now you can use IIC tool to read temp-sensor's register to get the temperature.

```
sudo apt install -y i2c-tools
sudo i2cdump -f -y 8 0x49
```

```
cupcake2@cupcake2-System-Product-Name:/opt/autotest/Basic$ sudo i2cdump -y -f 8 0x49
[sudo] password for cupcake2:
No size specified (using byte-data access)
   0  1  2  3  4  5  6  7  8  9  a  b  c  d  e  f    0123456789abcdef
00: 27 60 4b 50 17 06 00 00 27 60 4b 50 17 06 00 00    ` `KP??.. ` `KP??..
10: 27 60 4b 50 17 06 00 00 27 60 4b 50 17 06 00 00    ` `KP??.. ` `KP??..
20: 27 60 4b 50 17 06 00 00 27 60 4b 50 17 06 00 00    ` `KP??.. ` `KP??..
30: 27 60 4b 50 17 06 00 00 27 60 4b 50 17 06 00 00    ` `KP??.. ` `KP??..
40: 27 60 4b 50 17 06 00 00 27 60 4b 50 17 06 00 00    ` `KP??.. ` `KP??..
```

Or use i2cget to read register:

```
sudo i2cget -y 8 0x49 0
sudo i2cget -y 8 0x49 1
```

9.5.1.1 Temperature Register (address = 00h) [default reset = 0000h]

The temperature register of the TMP1075 is a 12-bit, read-only register that stores the result of the most recent conversion (see [Figure 9-11](#)). Data is represented in binary two's complement format. The first 12 bits are used to indicate temperature, with all remaining bits equal to zero. The least significant byte does not have to be read if that information is not needed. Following power-up or reset, the temperature register value is 0°C until the first conversion is complete.

Figure 9-11. Temperature Register

15	14	13	12	11	10	9	8
T11	T10	T9	T8	T7	T6	T5	T4
R-0	R-0	R-0	R-0	R-0	R-0	R-0	R-0
7	6	5	4	3	2	1	0
T3	T2	T1	T0	0	0	0	0
R-0	R-0	R-0	R-0	R-0	R-0	R-0	R-0

Table 9-7. Temperature Register Field Description

BIT	FIELD	TYPE	RESET	DESCRIPTION
15:4	T[11:0]	R	000h	12-bit, read-only register that stores the most recent temperature conversion results.
3:0	—	R	0h	Not used

Temperature is:

```
0x2760>>4 = 0x276
0x276*0.0625 = 39.375 degree centigrade
```

Table 9-1. Temperature Data Format

TEMPERATURE (°C)	DIGITAL OUTPUT	
	BINARY	HEX
127.9375	0111 1111 1111 0000	7FF0
100	0110 0100 0000 0000	6400
80	0101 0000 0000 0000	5000
75	0100 1011 0000 0000	4B00
50	0011 0010 0000 0000	3200
25	0001 1001 0000 0000	1900
0.25	0000 0000 0100 0000	0040
0.0625	0000 0000 0001 0000	0010
0	0000 0000 0000 0000	0000
-0.0625	1111 1111 1111 0000	FFF0
-0.25	1111 1111 1100 0000	FFC0
-25	1110 0111 0000 0000	E700
-50	1100 1110 0000 0000	CE00
-128	1000 000 0000 0000	8000

POE Power Control

POE power control is also connected to IIC, it's address is 0x20. If you want to manually control POE power output, you will need to set controller (0x12) to manual mode, then write control register(0x19) to power on or off POE port.

First, get the IIC bus for POE controller:

```
ls /sys/bus/pci/devices/*/i2c_designware.2*/ | grep i2c
cupcake2@cupcake2-System-Product-Name:~$ ls /sys/bus/pci/devices/*/i2c_designware.2*/ | grep i2c
i2c-5
```

The IIC bus is 5. To disable POE output:

```
sudo i2cset -y 5 0x20 0x12 0x55 #set 0x12 to 0x55, change to
manual mode
sudo i2cset -y 5 0x20 0x19 0xF0 #set 0x19 to 0xF0, to disable
power
sudo i2cset -y 5 0x20 0x19 0x0F #set 0x19 to 0x0F, to enable
power
```

Watchdog

1. Run command to check if driver can be loaded successfully.

```
sudo modprobe iTCO_wdt
```

Please provide a password if required by the system.

2. Check the log output by command:

```
sudo dmesg | grep -i iTCO
[ 1806.614626] iTCO_vendor_support: vendor-support=0
[ 1806.622542] iTCO_wdt iTCO_wdt: Found a Intel PCH TCO device (Version=6, TCOBASE=0x0400)
[ 1806.622825] iTCO_wdt iTCO_wdt: initialized. heartbeat=30 sec (nowayout=0)
```

Log would show similar as above output.

3. Install watchdog program.

```
Sudo apt install watchdog
```

4. Modify the following configurations files:

```
/etc/default/watchdog
change:      watchdog_module="none"
to:         watchdog_module="iTCO_wdt"
```

from:

```
# Load module before starting watchdog
watchdog_module="none"
# Specify additional watchdog options here (see manpage).
```

to:

```
# Load module before starting watchdog
watchdog_module="iTCO_wdt"
# Specify additional watchdog options here (see manpage).
```

5. Modify the /etc/watchdog.conf to

```
uncomment line: watchdog-device = /dev/watchdog
```

from:

```
# Uncomment this to use the watchdog device driver access "file".
#watchdog-device                = /dev/watchdog
```

to:

```
# Uncomment this to use the watchdog device driver access "file".
watchdog-device                = /dev/watchdog
```

You can change other watchdog configurations in this /etc/watchdog.conf file.

6. Now start the watchdog service and check the status:

```
sudo systemctl start watchdog
sudo systemctl status watchdog
```

```
cupcake2@cupcake2-System-Product-Name:~$ sudo systemctl status watchdog
● watchdog.service - watchdog daemon
   Loaded: loaded (/lib/systemd/system/watchdog.service; disabled; vendor preset: enabled)
   Active: active (running) since Mon 2023-12-25 13:56:26 CST; 4s ago
     Process: 14369 ExecStartPre=/bin/sh -c [ -z "${watchdog_module}" ] || [ "${watchdog_module}" = "none" ] || /sbin/modprobe swatchdog_module (code=exited, status=0/SUCCESS)
     Process: 14371 ExecStart=/bin/sh -c [ $run_watchdog != 1 ] || exec /usr/sbin/watchdog swatchdog_options (code=exited, status=0/SUCCESS)
    Main PID: 14373 (watchdog)
      Tasks: 1 (limit: 18225)
     Memory: 580.0K
           CPU: 11ms
    CGroup: /system.slice/watchdog.service
            └─14373 /usr/sbin/watchdog

12月 25 13:56:26 cupcake2-System-Product-Name watchdog[14373]: interface: no interface to check
12月 25 13:56:26 cupcake2-System-Product-Name watchdog[14373]: temperature: no sensors to check
12月 25 13:56:26 cupcake2-System-Product-Name watchdog[14373]: no test binary files
12月 25 13:56:26 cupcake2-System-Product-Name watchdog[14373]: no repair binary files
12月 25 13:56:26 cupcake2-System-Product-Name watchdog[14373]: error retry time-out = 60 seconds
12月 25 13:56:26 cupcake2-System-Product-Name watchdog[14373]: repair attempts = 1
12月 25 13:56:26 cupcake2-System-Product-Name watchdog[14373]: alive=/dev/watchdog heartbeat=[none] to-root no_act=no force=no
12月 25 13:56:26 cupcake2-System-Product-Name watchdog[14373]: watchdog now set to 60 seconds
12月 25 13:56:26 cupcake2-System-Product-Name watchdog[14373]: hardware watchdog identity: iTCO_wdt
12月 25 13:56:26 cupcake2-System-Product-Name systemd[1]: Started watchdog daemon.
lines 1-22/22. (END)
```

7. Enable autostart of the watchdog service

```
sudo systemctl enable watchdog
```

NOTE: save your work before you do follow steps:

8. Reboot and verify the driver was load automatically.

```
sudo reboot  
dmesg | grep -i iTCO
```

9. Simulate kernel panic as root user (Optional, test purpose):

```
sudo su  
echo 1 > /proc/sys/kernel/sysrq  
echo c > /proc/sysrq-trigger
```

The watchdog should reboot the system with the watchdog timeout value.

Suspend HOW TO

Suspend (S3, Suspend to memory) can be enabled by the steps below.

```
sudo apt install pm-utils
```

Goto SUSPEND(S3) mode:

```
sudo pm-suspend
```

When go into SUSPEND mode, the monitor will go power-save state. and press the power button or any key on keyboard can wake up system.

POE Camera Test (non-AI)

1. Start the cupcake system and login.
2. Open terminal as root user and check list of available 'dhcp' connections using below in Terminal.

```
cupcake@cupcake:~$ sudo su
[sudo] password for cupcake:
root@cupcake/home/cupcake# dhcp-lease-list
```

3. Output should look like below.

```
cupcake@cupcake:~$ sudo su
[sudo] password for cupcake:
root@cupcake:/home/cupcake# dhcp-lease-list
To get manufacturer names please download http://standards.ieee.org/regauth/oui/oui.txt to /usr/local/etc/oui.txt
Reading leases from /var/lib/dhcp/dhcpd.leases
=====
MAC                IP                hostname          valid until      manufacturer
-----
00:40:8c:b9:4b:0a  192.168.5.196    axis-00408cb94   2024-01-24 21:27:00 -NA-
00:40:8c:ba:c5:9d  192.168.5.195    axis-00408cbac   2024-01-24 21:26:57 -NA-
00:40:8c:cd:d8:84  192.168.5.150    axis-00408ccdd   2024-01-24 21:27:00 -NA-
root@cupcake:/home/cupcake#
```

4. Open browser to Camera's IP address like <http://192.168.5.150> as showed above. Then login in with correct username and password preset by your IP camera.
5. Now you should be able to watch video stream from POE Camera.

You can also start streaming video from IP camera by using RTSP protocol. You can install VLC player first, then open the stream.

Enter the RTSP stream network URL containing information in the below format in wizard. For this instance, we have used AXIS POE based cameras.

```
rtsp://<username>:<password>@<DHCP cam IP addr>/axis-media/media.amp
```

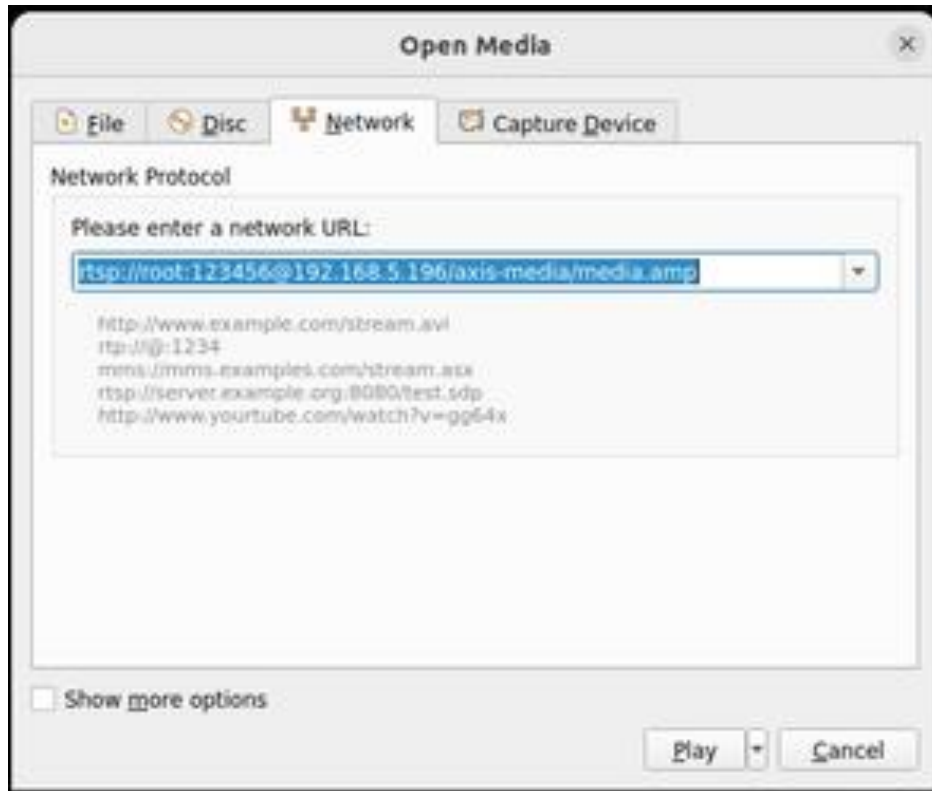

NOTE: The RSTP stream URL syntax may differ between camera vendors, User must review camera's product manual and user guide for additional information.

URLs to AI HW SDK's, Model Zoos (Neural Nets) and other Software

Hailo.ai:

<https://developer.hailo.ai/developer-zone/>

Blaize:

<https://blaize.freshdesk.com/support/login>

DeGirum:

<https://docs.degirum.com/content/index.html>

Brainchip:

<https://support.brainchip.com/portal/en/signin>

DeepX:

<https://my.deepx.app/en/login>

Mechanical Dimensions

1. Package weight (Inner Box) - 5.15 lbs.
2. Product weight (Cupcake chassis + fully assembled PCBA) - 3.05 lbs.
3. Product Packaging Dimensions (Inner Box) - 372 mm x 250 mm x 88 mm
4. Product dimensions (Cupcake chassis + fully assembled PCBA) - 170.00 x 158.19 x 49.10 mm

Mechanical Diagrams

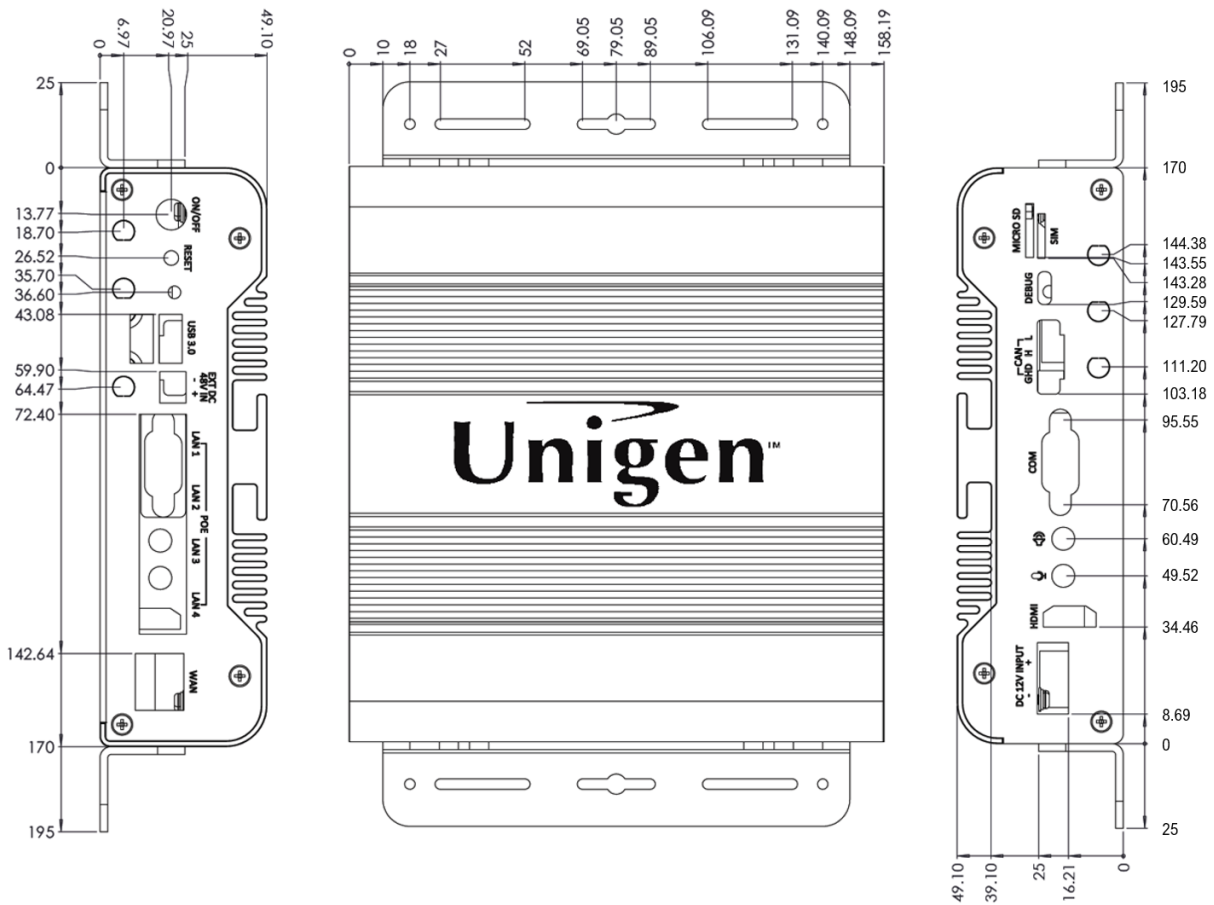

This document is provided “as is” with no warranties whatsoever, including any warranty of merchantability, non-infringement, fitness for any particular purpose, or any warranty otherwise arising out of any proposal, specification or sample.

Unigen Corporations disclaims all liability, including liability for infringement of any proprietary rights, relating to use of information in this document. No license, expressed or implied, by estoppels or otherwise, to any intellectual property rights is granted herein.

Third-party brands, names, and trademarks are the property of their respective owners.

Unigen™ and the Unigen logo are trademarks of Unigen Corporation. Copyright © 2024 by Unigen Corporation. All rights reserved. Unigen Corporation (“Unigen”) owns all right, title and interest in the property and products described herein, unless otherwise indicated. No part of this document may be translated to another language or produced or transmitted in any form or by any information storage and retrieval system without written permission from Unigen.

Unigen Corporation
39730 Eureka Drive
Newark, CA 94560
1-510-896-1818
sales@unigen.com
<http://www.unigen.com/>